

18

Hawker Tempest Mk V

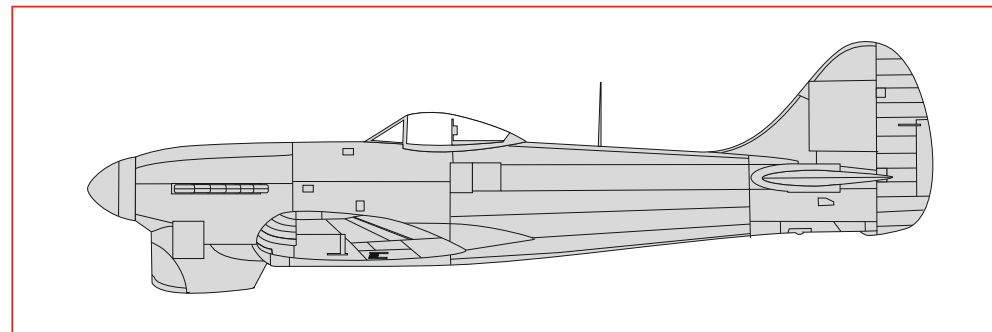
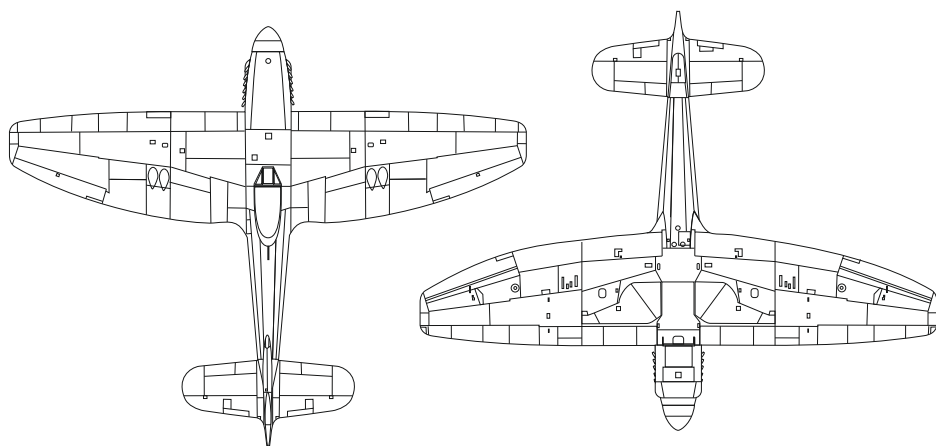
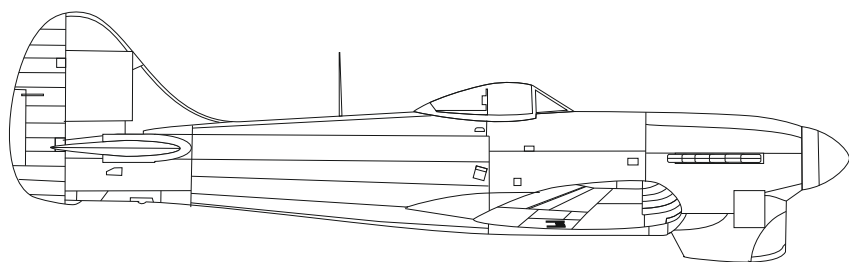
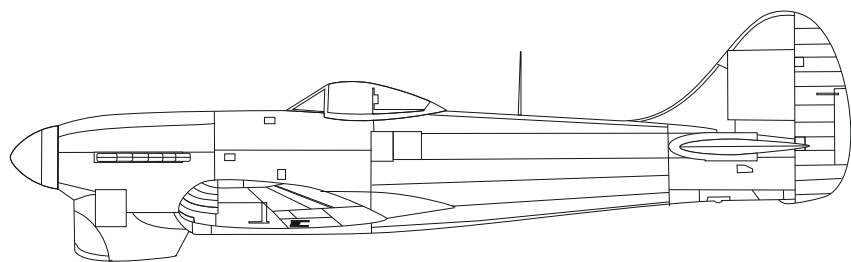

Hawker Tempest Mk V

Historie

Hawker Tempest (v angličtině bouře) byl velmi výkonným britským jednomotorovým stíhacím letounem druhé světové války. První sériový Tempest Mk.V (JN729) byl zalétán 21. června 1943. Již od počátku výroby byly Mk.V vybaveny kapkovitým krytem kabiny a čtyřřadavciválcovým řadovým motorem Napier Sabre IIA o vzletovém výkonu 1603 kW. Prvních sto kusů Mk.V Series 1 bylo vyzbrojeno čtveřicí kanónů British Hispano Mk.II instalovaných v křídle, jejichž hlavně o 0,2 m přesahovaly náběžnou hranu. Další Tempesty Mk.V Series 2 obdržely kanóny Hispano Mk.V s kratší hlavní. Tempesty byly poprvé bojově nasazeny začátkem května 1944 nad Francií při útocích na dopravní systém a letiště. Letadla Tempest aspirovala díky své rychlosti i ostatním vlastnostem na titul nejlepší stíhačky Royal Air Force.

History

The Hawker Tempest was a very powerful British single-engine fighter aircraft of World War II. The first serial Tempest Mk.V (JN729) was flown on June 21, 1943. From the beginning of production, the Mk.V were equipped with a teardrop-shaped cabin cover and a twenty-four-cylinder inline engine Napier Sabre IIA with a takeoff power of 1603 kW. The first hundred pieces of the Mk.V Series 1 were armed with four British Hispano Mk.II cannons installed in the wing, whose barrel by 0.2 m exceeded the leading edge. Other Tempesty Mk.V Series 2 received Hispano Mk.V cannons with a shorter barrel. Tempests were first deployed in combat in early May 1944 over France during attacks on the transport system and airports. Thanks to its speed and other characteristics, Tempest aircraft aspired to the title of the best Royal Air Force fighter.



OPTIONAL
VOLITELNĚ



DRILL HOLE
VYVRTAT



SYMMETRICAL
SYMETRICKY



REMOVE
ODSTRANIT

Plastikové díly/
Plastic parts

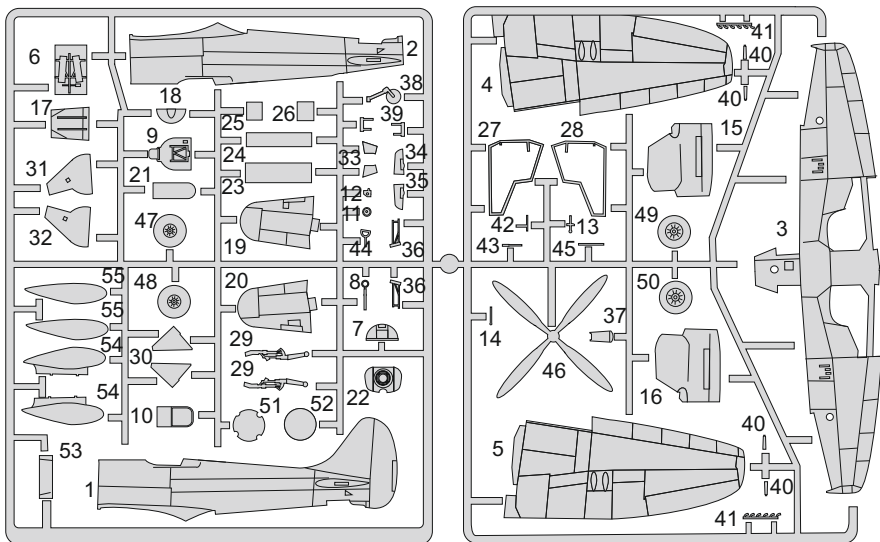

Průhledné díly/
Cleaner parts

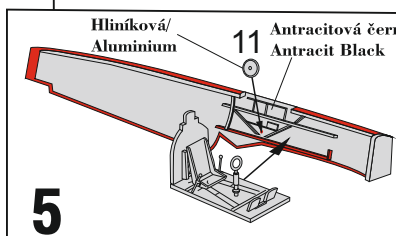
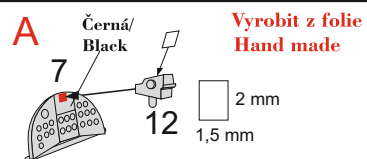
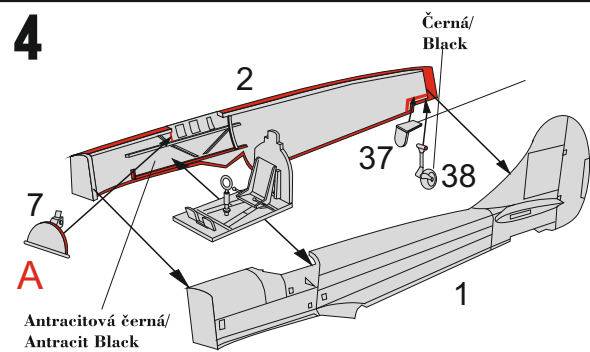
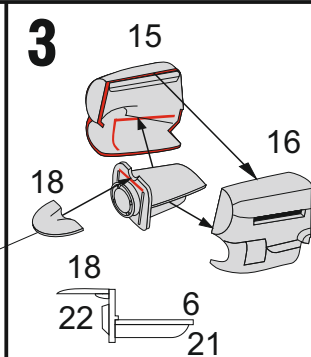
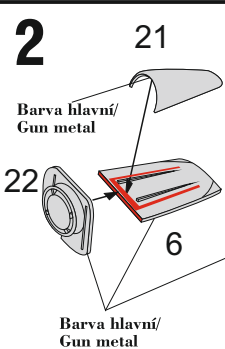
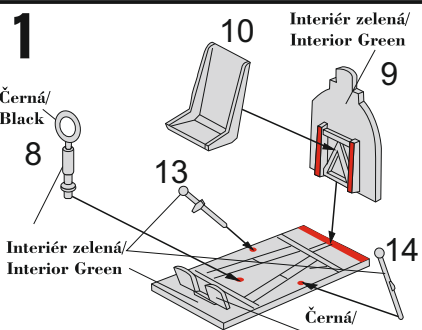

15

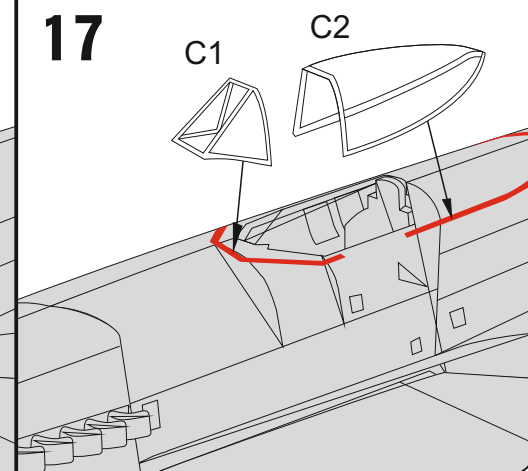
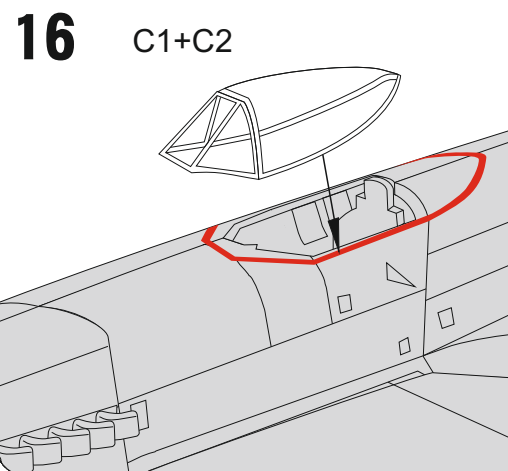
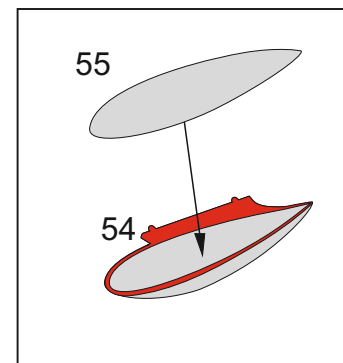
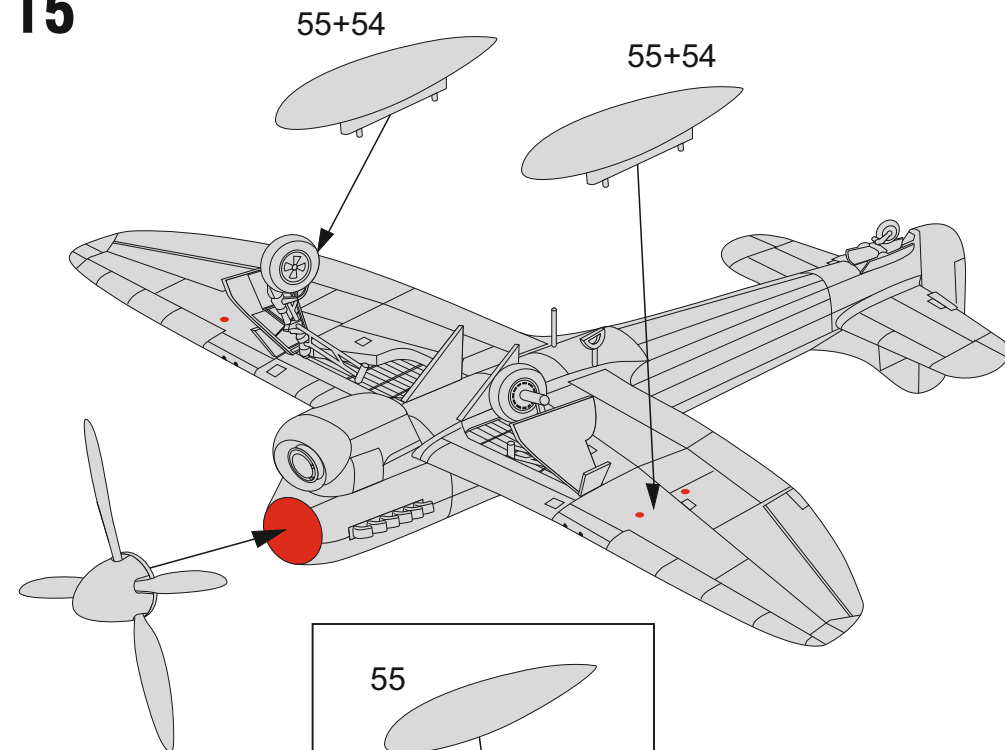

13

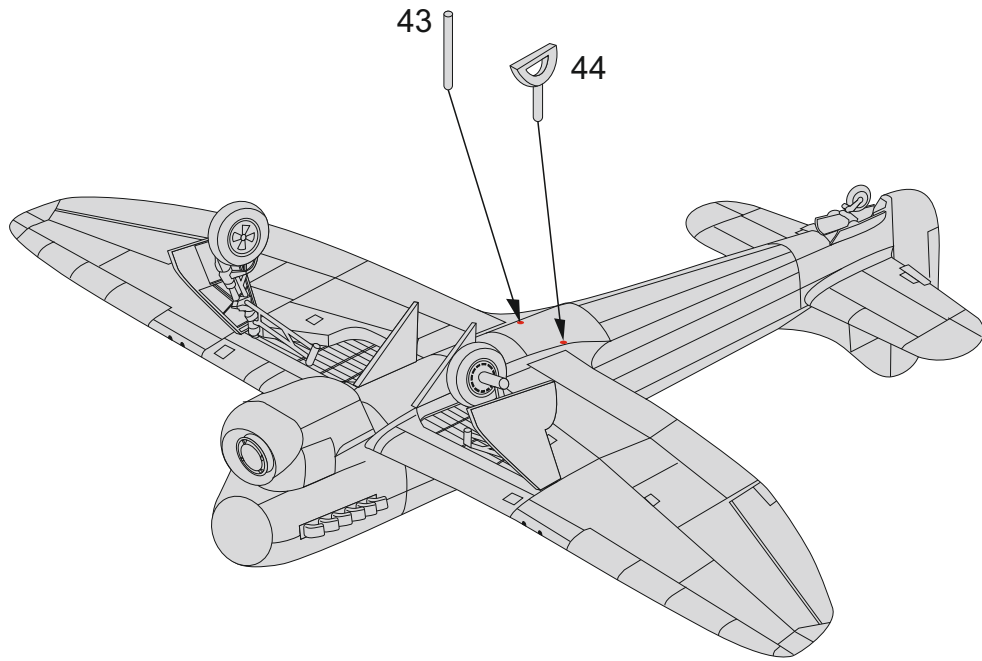

6

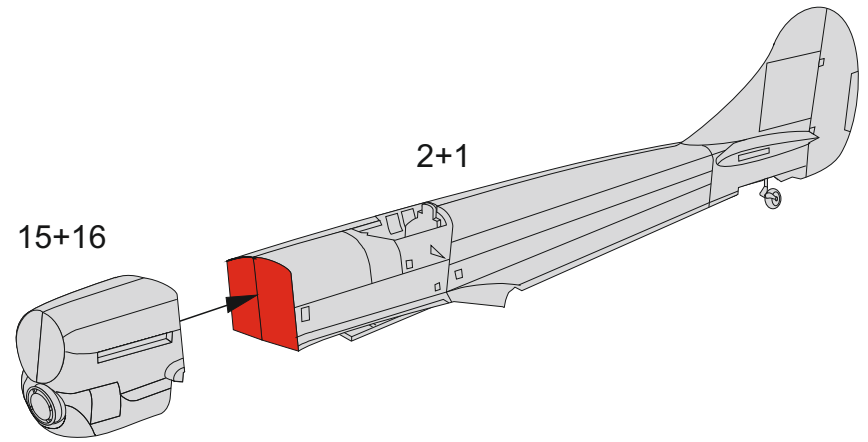

14

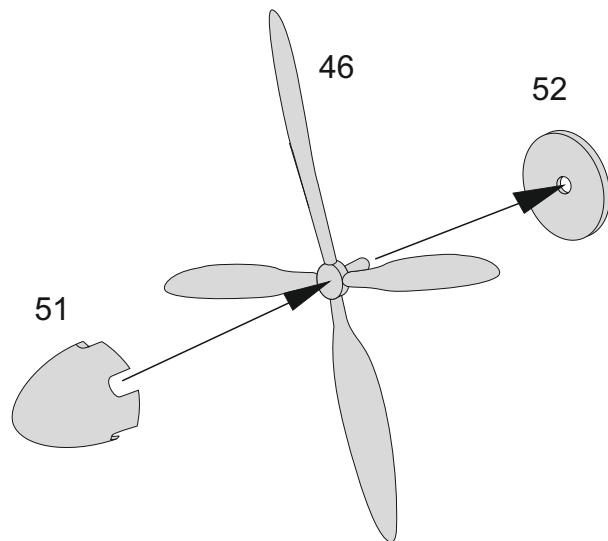

8

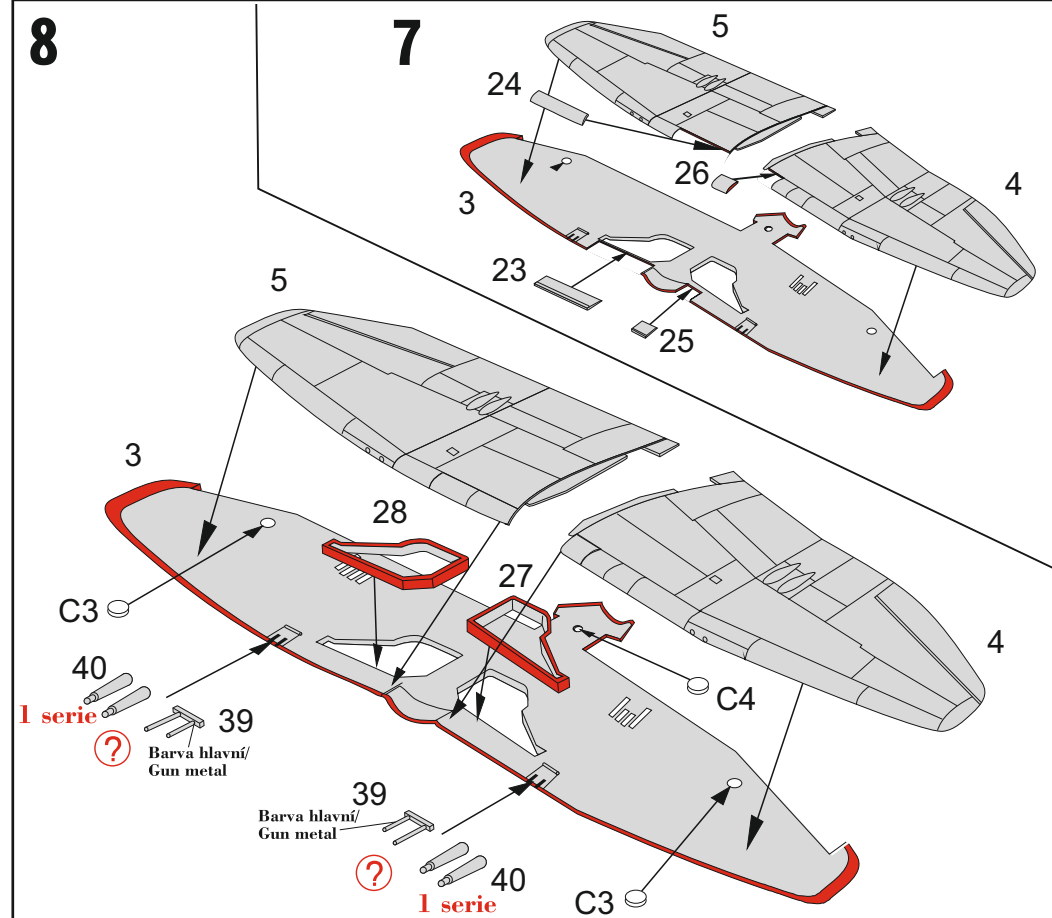

9

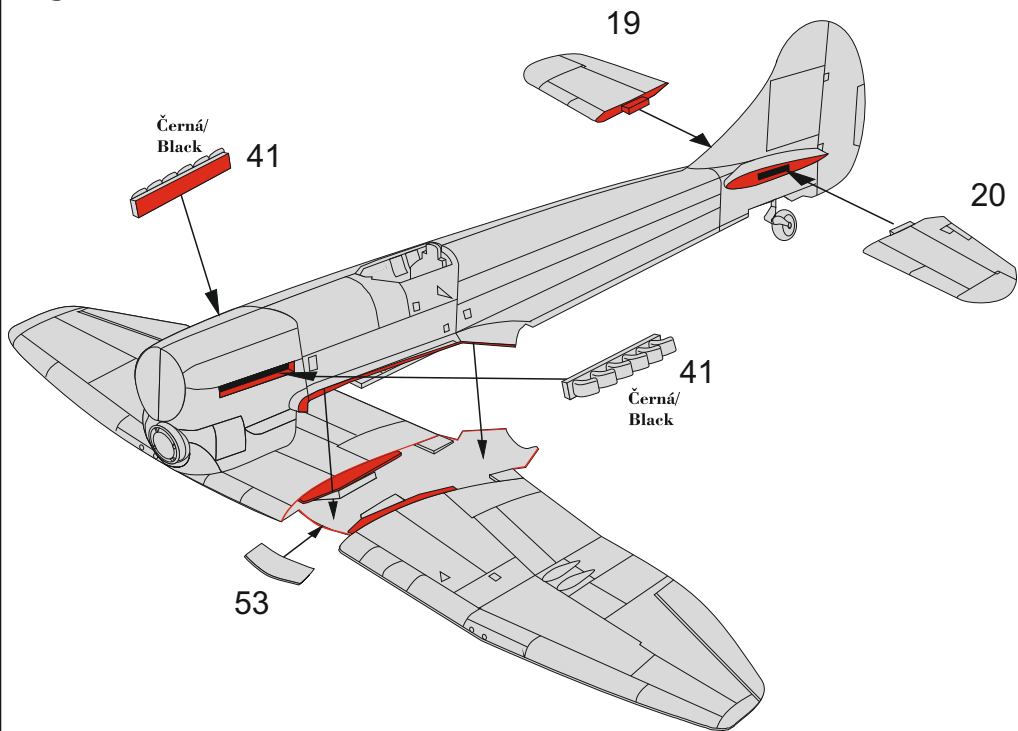

10

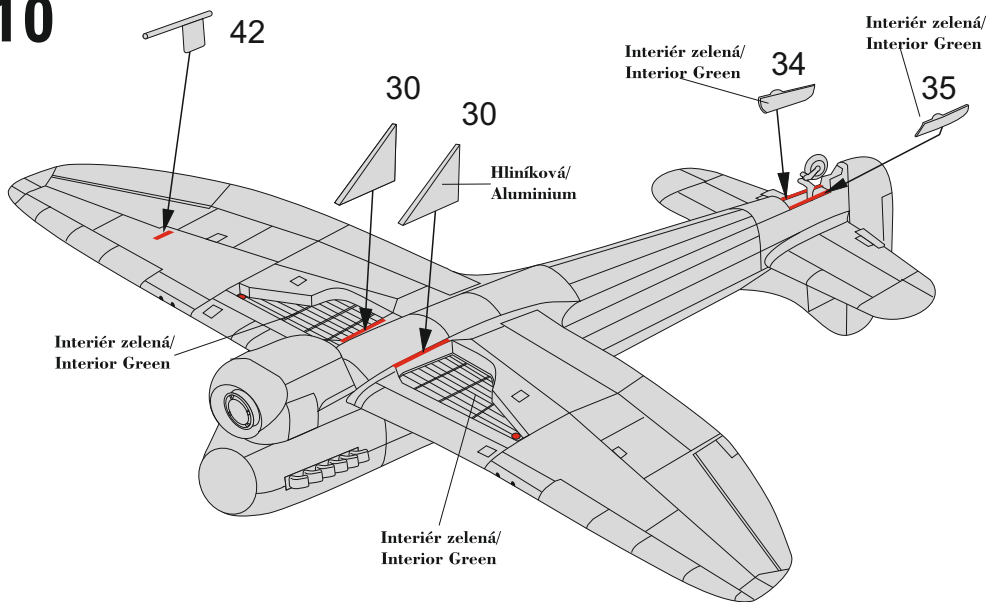

11

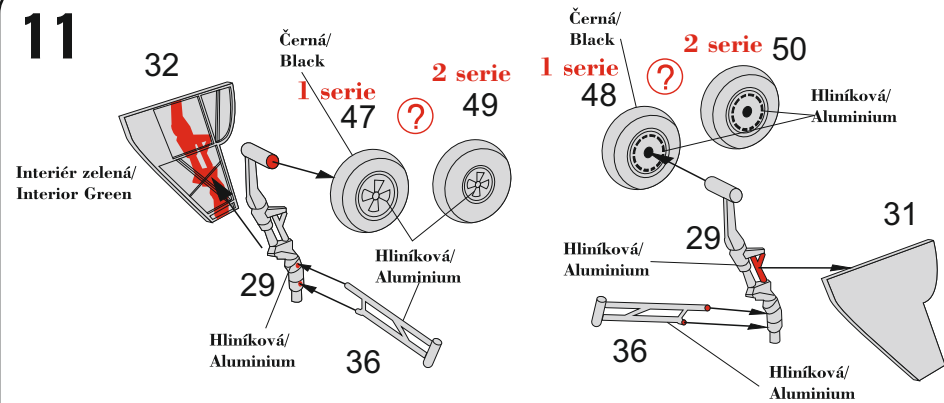

12

